

Eurotherm 2604 Controller

Advanced Process Controller/Programmer

Eurotherm Flexible Solutions



Product at a glance

The 2604 controller is a highly accurate, high stability process controller available in a single, dual or triple loop format. Features include setpoint programming and comprehensive selection of maths and logic functions.

It has a dual 5-digit display of process value and setpoint with an LCD panel for display of alarm messages, programmer and loop status information. User defined messages in the LCD panel simplify operation. The 2604 controller is a highly configurable product offering many features previously found only in programmable logic controllers. This allows systems to be implemented integrating the process control and logic functions of a machine, therefore simplifying system complexity and reducing the total system costs.

Configuration is achievable either via the front panel or using Eurotherm's iTools configuration software.

- 3 Control loops
- SP Programmer
- Customisable user interface
- Maths and logic functions
- Open communications

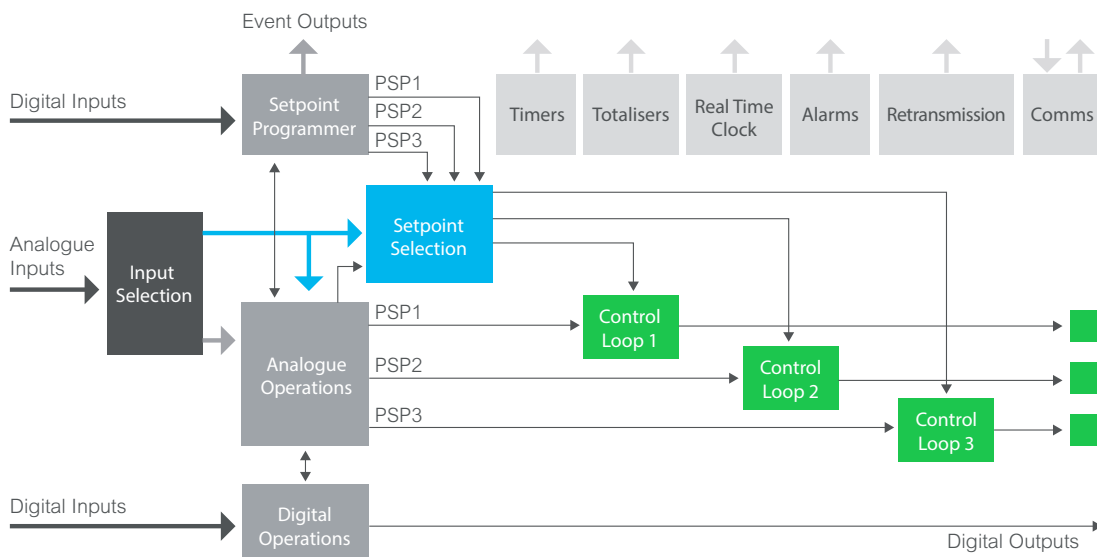

2604 Advanced Process Controller/Programmer Specifications

Control functions

- 3 Control loops
- PID, VP or ON/OFF
- Cascade, ratio or override
- Gain scheduling
- Configurable control strategies

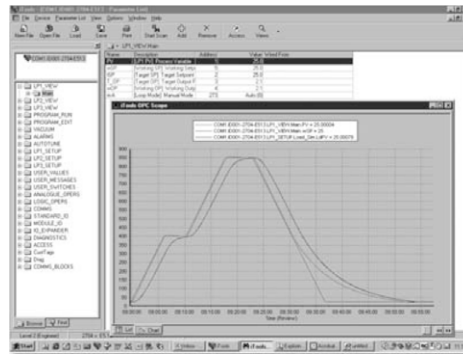

Eurotherm's advanced control algorithm gives precise straight-line control. Automatic tuning simplifies the commissioning procedure by performing a one shot tune to calculate the optimum PID values. To further optimise control especially in programmer applications, gain scheduling can be used to transfer control between up to six sets of PID values.

< iTools configuration software

IO Hardware

- 0.25uV PV input resolution
- Fixed and modular IO
- 250Vac isolation
- Expandable IO
- Easily upgraded

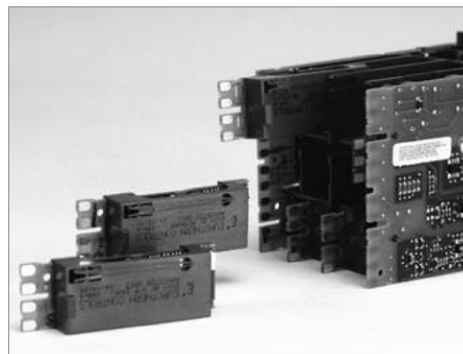

The 2604 controller incorporates a self correcting input circuit (INSTANT ACCURACY) to maximise accuracy and performance during initial warm up and changes in ambient temperature.

One universal and one high level analogue input, along with 10 digital IO are included as standard. Additionally, a further 5 IO module may be fitted providing very flexible input/output combinations. The series 2000IO expander unit can provide an additional 20 digital inputs and 20 digital outputs.

Setpoint programmer

- 50 Programs
- 3 Profiled setpoints/program
- 500 Segments
- 16 Event outputs



Ideal for applications such as atmosphere or vacuum furnaces, and environmental chambers. The 2604 controller user interface offers the user an extremely easy method of editing, selecting and running programs.

< Dual temperature/carbon programmer

iTools setpoint program editor

- Offline or online editing on PC
- Graphical representation
- Advanced editing functions
- Storage and retrieval of program files

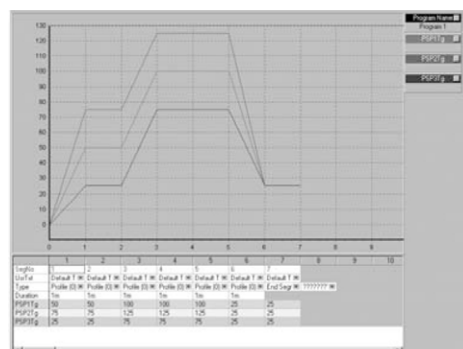

< iTools setpoint program editor

2604 Advanced Process Controller/Programmer Specifications

Toolkit functions

- Mathematical calculations
- Combinational logic
- Real time clock
- Timer functions

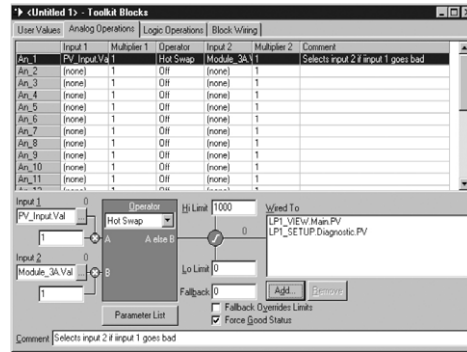

Operators include: Add, Subtract, Log, Exp, SQRT, AND, OR Max, Min, Select and many more.

ToolKit blocks allows the user to create custom solutions by internally wiring analogue and digital operations together in flexible ways. 24 analogue and 32 digital operations are available. Other functions are available including timers, totalisers and a real time clock.

< iTools toolkit block editor

I/O Expander

- 20 Logic inputs
- 20 Relay outputs

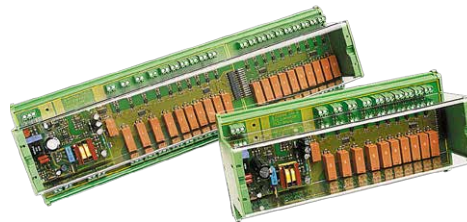

The 2000IO expander can increase the digital IO providing the option for greater remote operation of the programmer and expands the 2604 controller logic capability.

Slave communications

- Modbus™ RTU
- Profibus® DP
- DeviceNet®
- EI-Bisync

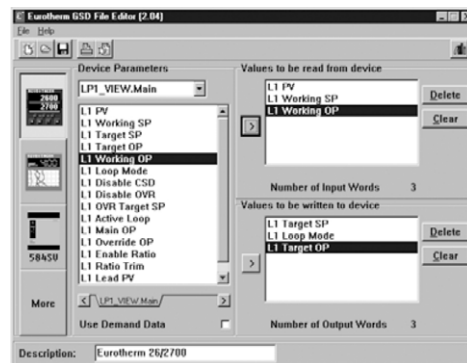

The 2604 controller supports two slave communication ports. Its modular build provides the user with a selection of communication protocols allowing easy integration into both PLC and PC supervisory systems.

When using Profibus DP a GSD file has to be created, containing the information relating to the instruments' parameters, that a Profibus master needs in order to communicate with its slave device. The GSD file for a 2604 controller is created using Eurotherm's GSD file editor.

< Profibus GSD editor

Master communications

- Modbus protocol
- 25 read/write parameters
- Expands available hardware
- Interfaces to most Modbus slaves

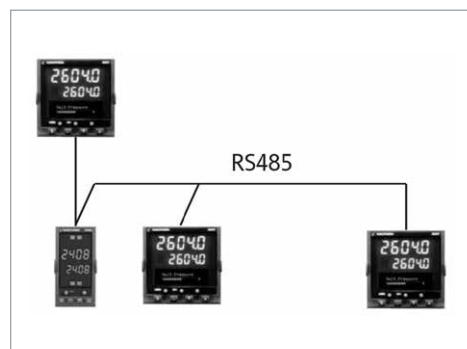

Master Modbus communications significantly increases the applications open to the 2604 controller. In its simplest form it can be used to retransmit a setpoint to a number of slave controllers in a multi-zone furnace.

2604 Advanced Process Controller/Programmer Specifications

% Relative humidity

- %RH or Dewpoint Measurement
- Pressure compensation
- Boost heat/cool
- Compressor timer
- Cooling bypass output

Ideal for use in applications where it is necessary to simulate the environmental conditions of temperature, humidity, altitude or light. The setpoint programmer is used to generate synchronised profiles of up to three variables. Other options allow configuration of signals to turn on a compressor, operate a bypass or operate further stages of heating and cooling.

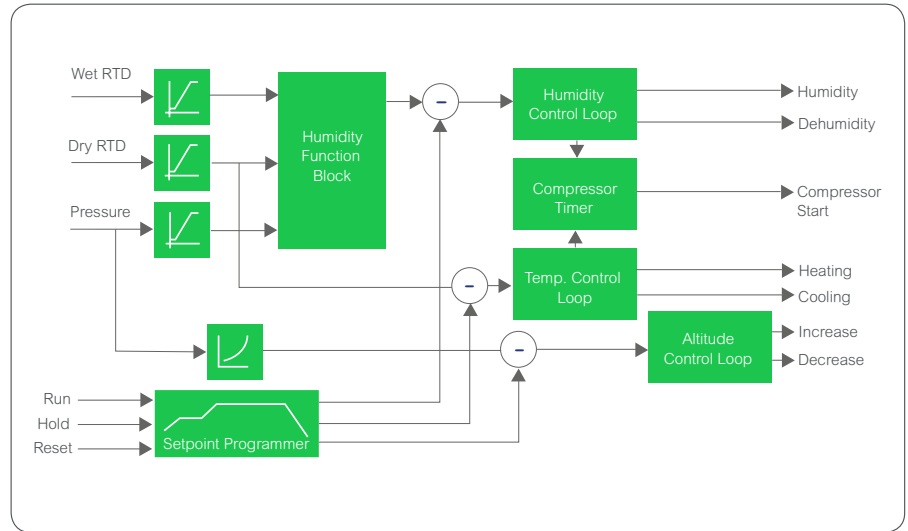

Carbon potential

- %CP, O₂ or Dewpoint measurement
- CO correction
- Probe burn off and sooting alarm
- Sooting alarm

Ideal for use in gas carburising furnaces where Zirconia probes are used to measure Carbon Potential. A three loop controller can be used to control furnace temperature, carbon potential and quench. The setpoint programmer is used in batch applications to generate synchronised temperature and carbon profiles.

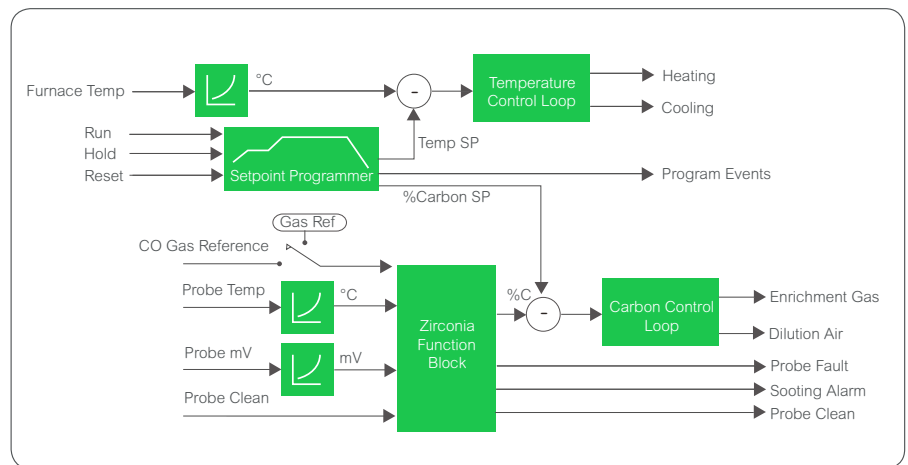

Melt pressure

- 350Ω Strain gauge input
- Transducer excitation
- Pressure alarms
- Screen blockage alarm
- Simple user calibration with shunt

Suitable for precision pressure control in the plastic extrusion industries. Additionally a second pressure transducer can be used to provide a differential pressure alarm when the screen starts to block. Various machine start up strategies can be used to perform a smooth transition from auto to manual mode.

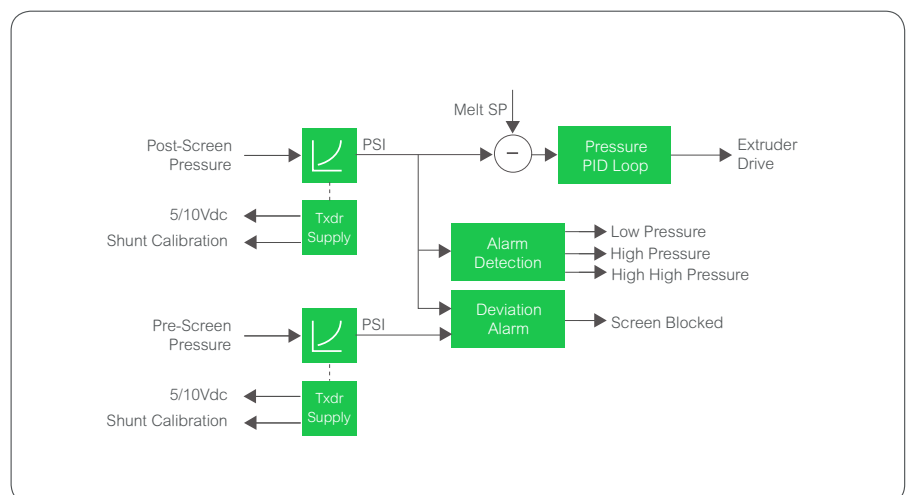

2604 Advanced Process Controller/Programmer Specifications

Technical Specifications

GENERAL		
Environmental performance	Temperature limits	Operation: 0 to 50°C Storage: -10 to 70°C
	Humidity limits	Operation: 5 to 95% RH non condensing Storage: 5 to 95% RH non condensing
	Panel sealing	IP65, Nema 4X
	Vibration	2g peak, 10 to 150Hz
	Altitude	<2000 metres
Atmospheres	Not suitable for use in explosive or corrosive atmosphere	
	Emissions and immunity	BS EN61326
Electromagnetic compatibility (EMC)	Suitable for domestic, commercial and light industrial as well as heavy industrial. (Domestic/light (Class B) emissions. Industrial (Class A) environmental immunity emissions. With Ethernet module fitted product only suitable for Class A emissions.	
Electrical safety	BS EN61010	Installation cat. II; Pollution degree 2
	INSTALLATION CATEGORY II: The rate impulse voltage for equipment on nominal 230V mains is 2500V. POLLUTION DEGREE 2: Normally, only non-conductive pollution occurs. Occasionally, however, a temporary conductivity caused by condensation shall be expected.	
Physical	Panel mounting	1/4 DIN
	Dimensions and weight	96W x 96H x 150D mm, 600g
	Panel cut-out dimensions	92W x 92Hmm
Control options	No. of loops	1, 2 or 3 loops
	Options	Cascade, Ratio or Override
	Modes	PID, ON/OFF or Valve Position
	Applications	Carbon Potential, Humidity
Approvals	CE, cUL listed (file E57766), Gost Suitable for use in Nadcap and AMS2750D applications under System Accuracy Test calibration conditions	

STANDARD I/O		
Precision PV input Accuracy	±0.1%	
Ranges	mV, mA, volts or RTD (PT100)	
Thermocouple types	J, K, I, N, R, S, B, PII, C, plus others	
Cold junction	Ext 0°C, 45°C or 50°C	
Analogue input	Allocation	1 fitted
	Accuracy	±0.1%
	Ranges	-10V to 10V or 0 to 20mA
Digital I/O	Types:	1 digital input, 7 Bi-directional input/outputs, 1 Changeover relay

MODULES		
Digital outputs	Types	Single Relay, Dual Relay, Single Triac, Dual Triac, Single Logic and Triple Logic module
	Allocation	Slot 1, 3, 4, 5 or 6 (Max 3 Triacs per unit)
Digital inputs	Types	Triple contact input, Triple logic input
	Allocation	Slot 1, 3, 4, 5 or 6
Analogue outputs	Types	DC Control or DC Retransmission (5 Max)
	Allocation	Slot 1, 3, 4, 5 or 6
	Range	0 to 20mA or 0 to 10Vdc

Dual Analogue outputs	Allocation	Slot 1, 4 or 5
	Range	4-20mA or 24Vdc transmitter PSU
High Resolution Analogue output	Allocation	Slot 1, 4 or 5
	Range	4-20mA and 24Vdc transmitter PSU
Transmitter PSU	Allocation	Slot 1, 3, 4, 5 or 6
	Transmitter	24Vdc @ 20mA
Transducer supply	Bridge voltage	Software selectable, 5 or 10Vdc
	Bridge resistance	300Ω to 15Kohms
Potentiometer input	Potentiometer resistance	330Ω to 150Kohms
	Allocation	Slot 3 or 6
Precision PV input (Module)	Accuracy	±0.1%
	Ranges	mV, mA, volts or RTD (PT100)
	Thermocouple types	J, K, T, L, N, R, S, B, PII, C, plus others
	Cold junction	Ext 0°C, 45°C or 50°C
Dual (Probe) input	Allocation	Slot 3 or 6
	Accuracy	±0.1%
	Ranges	mV, mA, volts or RTD (PT100)
	Thermocouple types	J, K, T, L, N, R, S, B, PII, C, plus others
Analogue input (Module)	Allocation	Slot 1, 3, 4 or 6
	Accuracy	±0.2%
	Ranges	mV, mA, volts or RTD (PT100)
	Thermocouple types	J, K, T, L, N, R, S, B, PII, C, plus others
Cold junction	Ext 0°C, 45°C or 50°C	

SETPOINT PROGRAMMER		
No. of profiles	1, 2 or 3 profiles	
No. of programs	50 programs max.	
No. of segments	500 time to target segments (max.) or 400 ramp rate segments (max.)	
Event outputs	Up to 16	
I/O Expander	10 I/O version	4 Changeover and 6 normally open relay contacts, 10 Logic inputs
	20 I/O version	4 Changeover and 16 normally open contacts, 20 Logic inputs

ADVANCED FUNCTIONS		
Application blocks	32 digital operations, 24 analogue operations, 12 user values	
Timers	4 ON pulse, OFF delay, one shot and min-ON	
Totalisers	4, trigger level and reset input	
Pattern generators	16 patterns each with 16 bits	
Real time clock	Day of the week and time	
Customisable screens	8 user screens	
User switches	8, toggle and momentary function	
Slave communications	Allocation	Slot H or J (DeviceNet/Profibus slot H only)
	Types	Profibus DP RS485, Modbus RTU RS485 (2 wire), RS485 (4 wire) or RS232, DeviceNet, EI-Bisync (subset of parameters)
Master communications	Allocation	Slot J
	Types	Modbus RTU RS485 (2 wire), RS485 (4 wire) or RS232
	Parameters	25 read/write

2604 Advanced Process Controller/Programmer Specifications

Hardware coding



Controller Type	Loop/Programs	I/O slots 1,3,4,5,6	Comms H	Manual	Technical Support
2604 Standard 2604f Profibus	First digit 1-- One loop 2-- Two loops 3-- Three loops Second digit -XX No programs -2- Twenty programs -5- Fifty programs Third digit -XX No programs --1 1 Profile --2 2 Profile --3 3 Profile	XX None fitted R4 Change over relay R2 2 Pin relay RR Dual relay T2 Triac TT Dual triac D4 DC Control D6 DC retransmission PV PV Input (Slots 3 & 6 only) TL Triple logic input TK Triple contact input TP Triple logic output MS 24Vdc t'mitter. PSU VU Pot. input G3 5Vdc t'ducer PSU G5 10Vdc t'ducer PSU AM Analogue input module (not in slot 5) DP Dual DC (probe) input ⁽⁴⁾ (Slots 3 and 6 only) DO Dual 4-20mA OP/24Vdc PSU (Slots 1, 4 & 5 only) LO Iso. single logic OP HR Hi Resolution DC retrans & 24Vdc PSU (Slots 1, 4 & 5 only)	XX None fitted A2 232 Modbus Y2 2W 485 Modbus F2 4W 485 Modbus AE 232 Bisync ⁽⁵⁾ YE 2W 485 Bisync ⁽⁵⁾ FE 4W 485 Bisync ⁽⁵⁾ PB Profibus DN DeviceNet	ENG English FRA French GER German SPA Spanish ITA Italian NED Dutch SWE Swedish	TS1 1 Hour TS2 2 Hours TS4 4 Hours TS8 8 Hours TS0 NONE
Supply Voltage VH 85-264Vac VL 20-29Vac/dc	Applications XX Standard ZC Zirconia		Comms J XX None fitted A2 232 Modbus Y2 2W 485 Modbus F2 4W 485 Modbus M1 232 Master M2 2W 485 Master M3 4W 485 Master	Toolkit Functions XX Standard U1 Toolkit level 1 ⁽²⁾ U2 Toolkit level 2 ⁽³⁾	Config Tools XX None IT iTools

Example Ordering Code

2604 - VH - 323 - XX - RR - PV - D4 - TP - PV - XX - A2 - XX - ENG - U1 - IT

This code describes a 3 loop controller with capability to store 20 three profile programs.

Supply voltage is 85-264Vac.

Modular hardware: 2 x PV input, 1 x Dual relay, 1 x DC control, 1 x Triple logic output, EIA-232 Comms. 16 analogue and 16 digital operations, iTools supplied with controller

Hardware notes:

1. Basic Controller/Programmer includes 8 digital registers, 4 timers and 4 totalisers.
2. Toolkit 1 includes 16 analogue, 16 digital, pattern generator, digital programmer, analogue switch and 4 user values.
3. Toolkit 2 includes Toolkit 1 plus extra 8 analogue, 16 digital/operations and 8 user values.
4. Dual analogue input suitable for Carbon Probes. (Inputs not isolated from each other).
5. EI-Bisync includes only a subset of parameters.
6. The HR module has 1 high resolution DC output and 1 24Vdc power supply.

2604 Advanced Process Controller/Programmer Specifications

Configuration coding (optional)

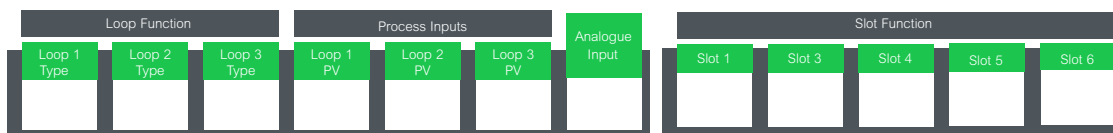

Loop Function	Process Inputs (Input type)	Analogue Input	Slot Function																																																																																																							
XXX None S Standard PID C Cascade R Ratio O Override(7) _PID PID control _ONF On/Off control _PIF PID/OnOff control _VP1 VP without feedback _VP2 VP with feedback	<table border="1"> <tr> <td>X None</td> <td>Q Custom curve (replace C)</td> </tr> <tr> <td>J J Thermocouple</td> <td>D D Thermocouple</td> </tr> <tr> <td>K K Thermocouple</td> <td>E E Thermocouple</td> </tr> <tr> <td>T T Thermocouple</td> <td>1 Ni/Ni18%Mo</td> </tr> <tr> <td>L L Thermocouple</td> <td>2 Pt20%Rh/Pt40%Rh</td> </tr> <tr> <td>N N Thermocouple</td> <td>3 W/W26%Re (Engelhard)</td> </tr> <tr> <td>R R Thermocouple</td> <td>4 W/W26%Re (Hoskins)</td> </tr> <tr> <td>S S Thermocouple</td> <td>5 W5%Re/W26%Re (Engelhard)</td> </tr> <tr> <td>B B Thermocouple</td> <td>6 W5%Re/W26%Re (Bucose)</td> </tr> <tr> <td>P Platinell II</td> <td>7 Pt10%Rh/Pt40%Rh</td> </tr> <tr> <td>C C Thermocouple</td> <td>8 Exergen K80</td> </tr> <tr> <td>Z RTD/Pt100</td> <td>I.R pyrometer</td> </tr> </table> <table border="1"> <tr> <td>A 4-20mA linear</td> </tr> <tr> <td>Y 0-20mA linear</td> </tr> <tr> <td>W 0-5Vdc linear</td> </tr> <tr> <td>G 1-5Vdc linear</td> </tr> <tr> <td>V 0-10Vdc linear</td> </tr> </table>	X None	Q Custom curve (replace C)	J J Thermocouple	D D Thermocouple	K K Thermocouple	E E Thermocouple	T T Thermocouple	1 Ni/Ni18%Mo	L L Thermocouple	2 Pt20%Rh/Pt40%Rh	N N Thermocouple	3 W/W26%Re (Engelhard)	R R Thermocouple	4 W/W26%Re (Hoskins)	S S Thermocouple	5 W5%Re/W26%Re (Engelhard)	B B Thermocouple	6 W5%Re/W26%Re (Bucose)	P Platinell II	7 Pt10%Rh/Pt40%Rh	C C Thermocouple	8 Exergen K80	Z RTD/Pt100	I.R pyrometer	A 4-20mA linear	Y 0-20mA linear	W 0-5Vdc linear	G 1-5Vdc linear	V 0-10Vdc linear	<table border="1"> <tr> <td>XXX None</td> </tr> <tr> <td>P2- PV Loop 2</td> </tr> <tr> <td>P3- PV Loop 3</td> </tr> <tr> <td>S1- SP Loop 1</td> </tr> <tr> <td>S2- SP Loop 2</td> </tr> <tr> <td>S3- SP Loop 3</td> </tr> <tr> <td>A1- Aux. PV Loop 1</td> </tr> <tr> <td>A2- Aux. PV Loop 2</td> </tr> <tr> <td>A3- Aux. PV Loop 3</td> </tr> <tr> <td>L1- Ratio Lead PV Loop 1</td> </tr> <tr> <td>L2- Ratio Lead PV Loop 2</td> </tr> <tr> <td>L3- Ratio Lead PV Loop 3</td> </tr> </table> <p>For input range select third digit from table 1</p>	XXX None	P2- PV Loop 2	P3- PV Loop 3	S1- SP Loop 1	S2- SP Loop 2	S3- SP Loop 3	A1- Aux. PV Loop 1	A2- Aux. PV Loop 2	A3- Aux. PV Loop 3	L1- Ratio Lead PV Loop 1	L2- Ratio Lead PV Loop 2	L3- Ratio Lead PV Loop 3	<table border="1"> <tr> <td>XXX Unconfigured</td> <td>Single DC outputs</td> </tr> <tr> <td>1-- Loop no. 1</td> <td>-H- PID Heat</td> </tr> <tr> <td>2-- Loop no. 2</td> <td>-C- PID Cool</td> </tr> <tr> <td>3-- Loop no. 3</td> <td>-T- PV retransmission</td> </tr> <tr> <td>Single relay, triac, logic</td> <td>-S- SP retransmission</td> </tr> <tr> <td>-HX Heat</td> <td>For output range select third digit from table 1</td> </tr> <tr> <td>-CX Cool</td> <td>Precision PV input</td> </tr> <tr> <td>Dual relay or triac</td> <td>-PV PV input module</td> </tr> <tr> <td>-HC PID Heat & Cool</td> <td>-PA Aux PV input (8)</td> </tr> <tr> <td>-VH VP Heat</td> <td>-PL Ratio lead input</td> </tr> <tr> <td>-AA FSH & FSH</td> <td>Analogue input</td> </tr> <tr> <td>-AB FSH & FSL</td> <td>-R- Setpoint</td> </tr> <tr> <td>-AC DH & DL</td> <td>For input range select third digit from table 1</td> </tr> <tr> <td>-AD FSH & DH</td> <td>Aux. & lead PV inputs</td> </tr> <tr> <td>-AE FSL & DL</td> <td>-L- Ratio lead input</td> </tr> <tr> <td>-AF FSL & FSL</td> <td>-B- Aux. PV input</td> </tr> <tr> <td>-AG FSH & DB</td> <td>For input range select third digit from table 1</td> </tr> <tr> <td>-AH FSL & DB</td> <td>Potentiometer input</td> </tr> <tr> <td>-AJ DB & DB</td> <td>-VF VP Heat feedback</td> </tr> <tr> <td>HHX Heat output for loops 1 & 2</td> <td>-RS Remote SP</td> </tr> <tr> <td>CCX Cool OP's loops 1 & 2</td> <td>Dual DC 4-20mA/24Vdc</td> </tr> <tr> <td>P12 Prog events 1 & 2</td> <td>PSU Output</td> </tr> <tr> <td>P34 Prog events 3 & 4</td> <td>HHX Heat output for loops 1 & 2</td> </tr> <tr> <td>P56 Prog events 5 & 6</td> <td>-HC Heat Cool</td> </tr> <tr> <td>P78 Prog events 7 & 8</td> <td>-HT CH1 Heat, CH2 PSU</td> </tr> <tr> <td>Triple logic output</td> <td>TTX Both channels PSU</td> </tr> <tr> <td>-HX CH1 Heat</td> <td>High Resolution DC OP</td> </tr> <tr> <td>-CX CH1 Cool</td> <td>-TA 4-20mA PV Retrans</td> </tr> <tr> <td>-HC CH1 Heat, CH2 Cool</td> <td>-TV 0-10V PV Retrans</td> </tr> <tr> <td>HHX Heat output loops 1 & 2</td> <td>-SA 4-20mA SP Retrans</td> </tr> <tr> <td>HHH Heat output for loops 1, 2 & 3</td> <td>-SV 0-10V SP Retrans</td> </tr> </table>	XXX Unconfigured	Single DC outputs	1-- Loop no. 1	-H- PID Heat	2-- Loop no. 2	-C- PID Cool	3-- Loop no. 3	-T- PV retransmission	Single relay, triac, logic	-S- SP retransmission	-HX Heat	For output range select third digit from table 1	-CX Cool	Precision PV input	Dual relay or triac	-PV PV input module	-HC PID Heat & Cool	-PA Aux PV input (8)	-VH VP Heat	-PL Ratio lead input	-AA FSH & FSH	Analogue input	-AB FSH & FSL	-R- Setpoint	-AC DH & DL	For input range select third digit from table 1	-AD FSH & DH	Aux. & lead PV inputs	-AE FSL & DL	-L- Ratio lead input	-AF FSL & FSL	-B- Aux. PV input	-AG FSH & DB	For input range select third digit from table 1	-AH FSL & DB	Potentiometer input	-AJ DB & DB	-VF VP Heat feedback	HHX Heat output for loops 1 & 2	-RS Remote SP	CCX Cool OP's loops 1 & 2	Dual DC 4-20mA/24Vdc	P12 Prog events 1 & 2	PSU Output	P34 Prog events 3 & 4	HHX Heat output for loops 1 & 2	P56 Prog events 5 & 6	-HC Heat Cool	P78 Prog events 7 & 8	-HT CH1 Heat, CH2 PSU	Triple logic output	TTX Both channels PSU	-HX CH1 Heat	High Resolution DC OP	-CX CH1 Cool	-TA 4-20mA PV Retrans	-HC CH1 Heat, CH2 Cool	-TV 0-10V PV Retrans	HHX Heat output loops 1 & 2	-SA 4-20mA SP Retrans	HHH Heat output for loops 1, 2 & 3	-SV 0-10V SP Retrans
X None	Q Custom curve (replace C)																																																																																																									
J J Thermocouple	D D Thermocouple																																																																																																									
K K Thermocouple	E E Thermocouple																																																																																																									
T T Thermocouple	1 Ni/Ni18%Mo																																																																																																									
L L Thermocouple	2 Pt20%Rh/Pt40%Rh																																																																																																									
N N Thermocouple	3 W/W26%Re (Engelhard)																																																																																																									
R R Thermocouple	4 W/W26%Re (Hoskins)																																																																																																									
S S Thermocouple	5 W5%Re/W26%Re (Engelhard)																																																																																																									
B B Thermocouple	6 W5%Re/W26%Re (Bucose)																																																																																																									
P Platinell II	7 Pt10%Rh/Pt40%Rh																																																																																																									
C C Thermocouple	8 Exergen K80																																																																																																									
Z RTD/Pt100	I.R pyrometer																																																																																																									
A 4-20mA linear																																																																																																										
Y 0-20mA linear																																																																																																										
W 0-5Vdc linear																																																																																																										
G 1-5Vdc linear																																																																																																										
V 0-10Vdc linear																																																																																																										
XXX None																																																																																																										
P2- PV Loop 2																																																																																																										
P3- PV Loop 3																																																																																																										
S1- SP Loop 1																																																																																																										
S2- SP Loop 2																																																																																																										
S3- SP Loop 3																																																																																																										
A1- Aux. PV Loop 1																																																																																																										
A2- Aux. PV Loop 2																																																																																																										
A3- Aux. PV Loop 3																																																																																																										
L1- Ratio Lead PV Loop 1																																																																																																										
L2- Ratio Lead PV Loop 2																																																																																																										
L3- Ratio Lead PV Loop 3																																																																																																										
XXX Unconfigured	Single DC outputs																																																																																																									
1-- Loop no. 1	-H- PID Heat																																																																																																									
2-- Loop no. 2	-C- PID Cool																																																																																																									
3-- Loop no. 3	-T- PV retransmission																																																																																																									
Single relay, triac, logic	-S- SP retransmission																																																																																																									
-HX Heat	For output range select third digit from table 1																																																																																																									
-CX Cool	Precision PV input																																																																																																									
Dual relay or triac	-PV PV input module																																																																																																									
-HC PID Heat & Cool	-PA Aux PV input (8)																																																																																																									
-VH VP Heat	-PL Ratio lead input																																																																																																									
-AA FSH & FSH	Analogue input																																																																																																									
-AB FSH & FSL	-R- Setpoint																																																																																																									
-AC DH & DL	For input range select third digit from table 1																																																																																																									
-AD FSH & DH	Aux. & lead PV inputs																																																																																																									
-AE FSL & DL	-L- Ratio lead input																																																																																																									
-AF FSL & FSL	-B- Aux. PV input																																																																																																									
-AG FSH & DB	For input range select third digit from table 1																																																																																																									
-AH FSL & DB	Potentiometer input																																																																																																									
-AJ DB & DB	-VF VP Heat feedback																																																																																																									
HHX Heat output for loops 1 & 2	-RS Remote SP																																																																																																									
CCX Cool OP's loops 1 & 2	Dual DC 4-20mA/24Vdc																																																																																																									
P12 Prog events 1 & 2	PSU Output																																																																																																									
P34 Prog events 3 & 4	HHX Heat output for loops 1 & 2																																																																																																									
P56 Prog events 5 & 6	-HC Heat Cool																																																																																																									
P78 Prog events 7 & 8	-HT CH1 Heat, CH2 PSU																																																																																																									
Triple logic output	TTX Both channels PSU																																																																																																									
-HX CH1 Heat	High Resolution DC OP																																																																																																									
-CX CH1 Cool	-TA 4-20mA PV Retrans																																																																																																									
-HC CH1 Heat, CH2 Cool	-TV 0-10V PV Retrans																																																																																																									
HHX Heat output loops 1 & 2	-SA 4-20mA SP Retrans																																																																																																									
HHH Heat output for loops 1, 2 & 3	-SV 0-10V SP Retrans																																																																																																									

General notes:

1. Loop 1 PV defaults to main PV input on microboard. Loop 2 and 3 PV inputs must be fitted in I/O slots 3 or 6 or be assigned to the analogue input.
2. Alarm configuration refers to loop alarms only. One selection is allowed per loop. Additional alarms are available for the user to configure.
3. Thermocouple and RTD inputs assume sensor min and max values with no decimal point.
4. Linear inputs are ranged 0-100%, no decimal point.
5. Temperature units will be °C unless ordered by USA where °F will be used.
6. Remote setpoints assume loop min & max ranges.
7. VP1, VP2, VP3 and VP4 are not available with override function.
8. For Cascade and Override inputs only.
9. HR module should be used in feedback mode, please refer to TIBC160.

2604 Advanced Process Controller/Programmer Specifications

Dimensional details

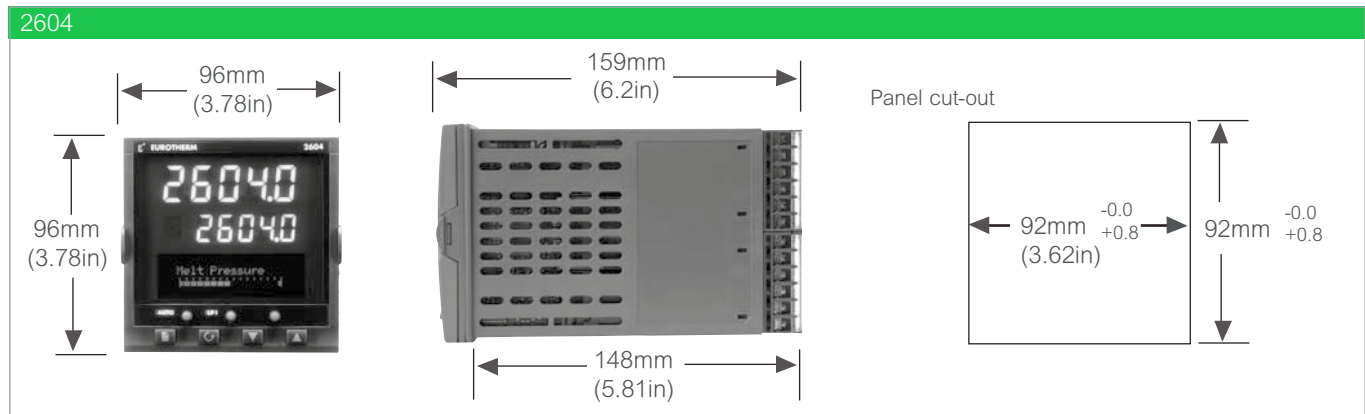

Rear terminal connections

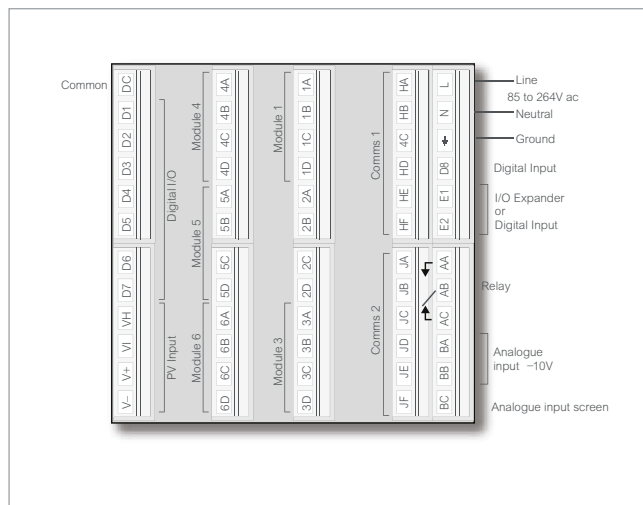

Isolation

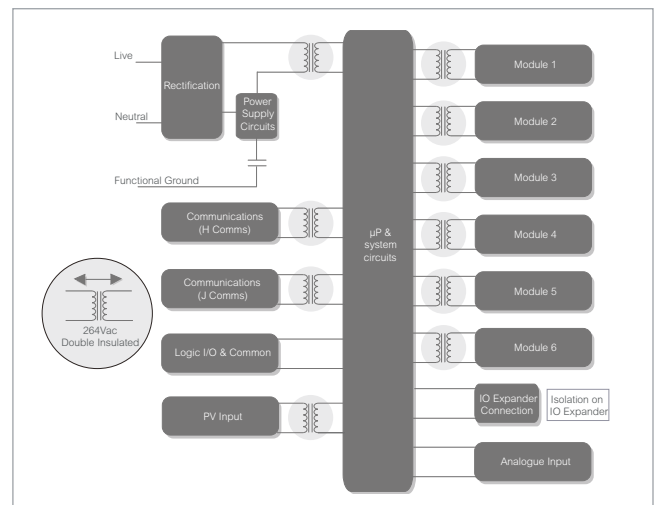

Eurotherm Limited
 Faraday Close, Durrington,
 Worthing, West Sussex BN13 3PL, UK
 Phone: + 44 (0)1903 268500
 eurotherm.co.uk



Life Is On

Eurotherm.
 by Schneider Electric